

Patent pending on package assembly

- 36V to 75V Input Range
- Programmable Output Voltage Range 1.3V to 3.5V
- -40° to +100°C Operating Temp
- 1500 VDC Isolation
- 88% Efficiency
- Remote On/Off
- Differential Remote Sense
- N+1 Current Sharing
- Over-Current Protection
- Over-Temperature Protection
- Over-Voltage Protection
- Solderable Copper Case

The PT4481 Excalibur™ module combines state-of-the-art power conversion technology with un-paralleled flexibility. Operating off a standard 48V telecom input, the PT4481 provides a full 100W output at load currents up to 30A, and over the programmable output voltage range of 1.3V to 3.5V.

The PT4481 features high efficiencies, ultra-fast transient response, and the capability for true N+1 current sharing. This product also includes output short circuit and over-temperature protection.

Standard Application

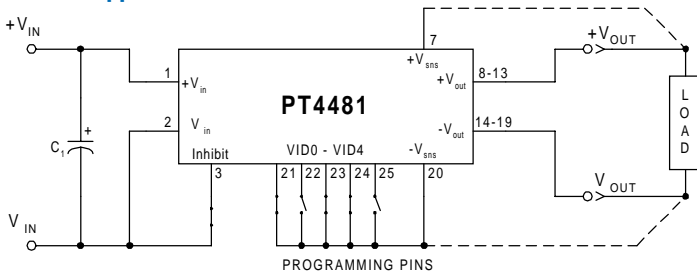

- C₁ = Optional 33µF, 100V electrolytic capacitor
- Programming pins, VID0–VID4, are shown configured for V_o = 3.3V
- For normal operation, pin 3 (Inhibit) must be connected to -V_{in}.
- For operation in N+1 configuration, consult the related application note.
- Pins 6 & 26 are used for N+1 configurations only

Specifications

Characteristics (T _a =25°C unless noted)	Symbols	Conditions (V _{in} =48V, V _o =3.3V unless noted)	PT4481			
			Min	Typ	Max	Units
Output Current	I _o	Over V _{in} range	0	—	30	A
Current Limit	I _{cl}	V _{in} = 36V	—	35	—	A
Current Sharing		Single line referenced to -V _{sense}	—	—	±10	%
Input Voltage Range	V _{in}	I _o = 0 to max I _o	36	48	75	V
Output Voltage Tolerance	ΔV _o	Over V _{in} Range T _A = -40 to +100°C Baseplate	—	±1.0	±2.0	%V _o
Line Regulation	Reg _{line}	Over V _{in} range @ max I _o	—	±0.1	±1.0	%V _o
Load Regulation	Reg _{load}	0 to 100% of I _o max	—	±0.5	±1.0	%V _o
V _o Ripple/Noise	V _n	I _o = I _o max	V _o > 2.0V V _o ≤ 2.0V	— 60	— 75	— mV _{pp}
Transient Response	t _{tr}	50% to 75% I _o max @ 0.1A/µs	—	N/A	—	µSec
		V _o over/undershoot (no ext caps)	—	1.0	—	%V _o
		50% to 100% I _o max @ 1.0A/µs	—	75	—	µSec
		V _o over/undershoot (no ext. caps)	—	6	—	%V _o
V _o Rise Time	V _{otr}	At turn-on	—	—	10	mSec
Efficiency	η	I _o =15A	—	88.5	—	%
Switching Frequency	f _o	—	—	300	—	kHz
Remote On/Off	Off On	Open or 2.5 to 5.1 VDC above -V _{in} Short or 0 to 0.8 VDC above -V _{in}				
Over-Voltage Protection	OVP	Shutdown and latch off	—	125	—	%V _o
Isolation	—	—	1500	—	—	VDC
Maximum Operating Temperature Range	T _c	Measured at center of case	-40	—	+100	°C
Over-Temperature Shutdown Point	OTP	Case temperature - Auto reset	—	+105	—	°C
Reliability	MTBF	Per Bellcore TR-332 50% stress, t = 40°C, ground benign	1.4	—	—	10 ⁶ Hrs
Mechanical Shock	—	Per Mil-STD-883D, Method 2002.3, 1mS, Half-sine, mounted to a fixture	—	TBD	—	G's
Mechanical Vibration	—	Per Mil-STD-883D, Method 2007.2, 20-2000Hz, Soldered in a PC board	—	TBD	—	G's
Weight	—	—	—	90	—	grams

PT4481—48V

100 Watt 30 Amp Programmable Isolated DC-DC Converter

Pin-Out Information

Pin	Function	Pin	Function
1	+V _{in}	14	-V _{out}
2	-V _{in}	15	-V _{out}
3	Inhibit	16	-V _{out}
4	Do not connect	17	-V _{out}
5	Do not connect	18	-V _{out}
6	Sync	19	-V _{out}
7	+V _{sense}	20	-V _{sense}
8	+V _{out}	21	VID0
9	+V _{out}	22	VID1
10	+V _{out}	23	VID2
11	+V _{out}	24	VID3
12	+V _{out}	25	VID4
13	+V _{out}	26	Share

Programming Information

VID3	VID2	VID1	VID0	VID4=1 Vout	VID4=0 Vout
1	1	1	1	2.0V	1.30V
1	1	1	0	2.1V	1.35V
1	1	0	1	2.2V	1.40V
1	1	0	0	2.3V	1.45V
1	0	1	1	2.4V	1.50V
1	0	1	0	2.5V	1.55V
1	0	0	1	2.6V	1.60V
1	0	0	0	2.7V	1.65V
0	1	1	1	2.8V	1.70V
0	1	1	0	2.9V	1.75V
0	1	0	1	3.0V	1.80V
0	1	0	0	3.1V	1.85V
0	0	1	1	3.2V	1.90V
0	0	1	0	3.3V	1.95V
0	0	0	1	3.4V	2.00V
0	0	0	0	3.5V	2.05V

Logic 0 = Pin 20 potential (remote sense gnd)
 Logic 1 = Open circuit (no pull-up resistors)
 VID4 may not be changed while the unit is operating.

Ordering Information

PT4481□ = 1.3 to 3.5 Volts
 (For dimensions and PC board layout, see Package Styles 1200, 1210 and 1215.)

PT Series Suffix (PT1234X)

Case/Pin Configuration

Vertical Through-Hole	N
Horizontal Through-Hole	A
Horizontal Surface Mount	C

TYPICAL CHARACTERISTICS

PT4481, V_o = 3.3V (See Note A)

Efficiency vs Output Current

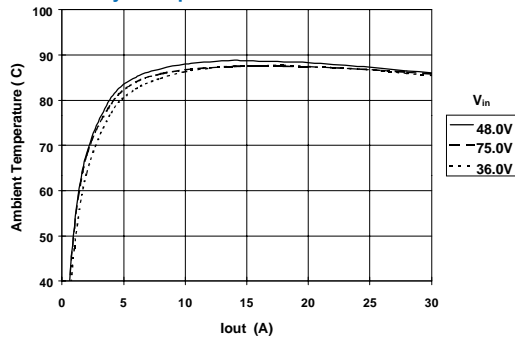

Safe Operating Area, V_{in} = 48V, V_o = 3.3V (See Note B)

PT4481, Stand Alone and w/o Heatsink

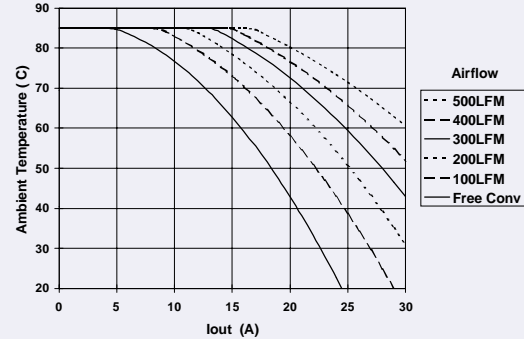

Ripple vs Output Current

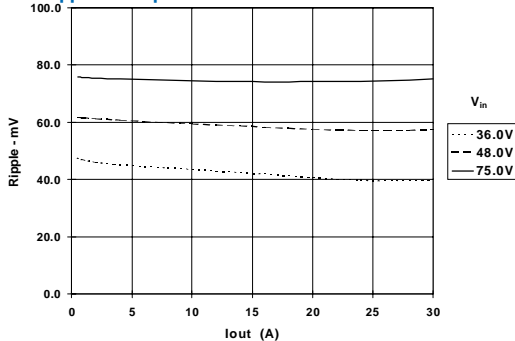

Power Dissipation vs Output Current

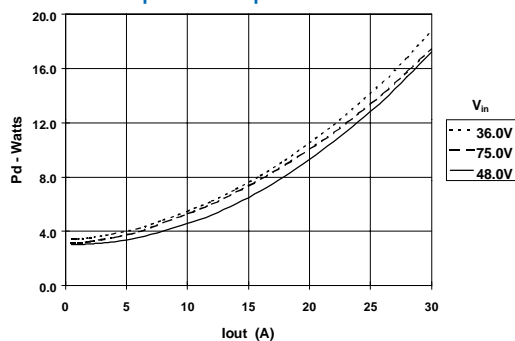

Note A: All data listed in the above graphs has been developed from actual products tested at 25°C. This data is considered typical data for the DC-DC Converter.

Note B: SOA curves represent operating conditions at which the temperature of the metal case is at or below the maximum specified 100°C

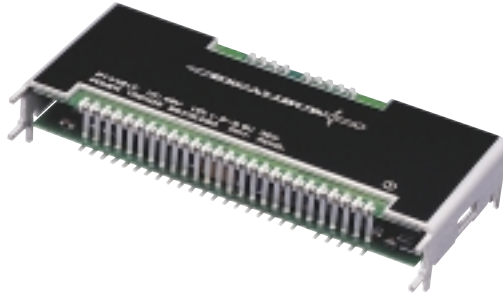

Patent pending on package assembly

- 36V to 75V Input Range
- Programmable Output Voltage Range: 1.3V to 3.5V
- -40° to +100°C Operating Temp
- 1500 VDC Isolation
- 88% Efficiency
- Remote On/Off
- Differential Remote Sense
- 60A Output with PT4499
- Over-Current Protection
- Over-Temperature Protection
- Over-Voltage Protection
- Solderable Copper Case

The PT4482 Excalibur™ module combines state-of-the-art power conversion technology with un-paralleled flexibility. Operating off a standard 48V telecom input, the PT4482 provides a full 100W output at load currents up to 30A, and over the programmable output voltage range of 1.3V to 3.5V. The output may be increased to 60A when used with the compatible PT4499 booster module.

The PT4482 features high efficiencies, ultra-fast transient response, and output short circuit and over-temperature protection.

Standard Application

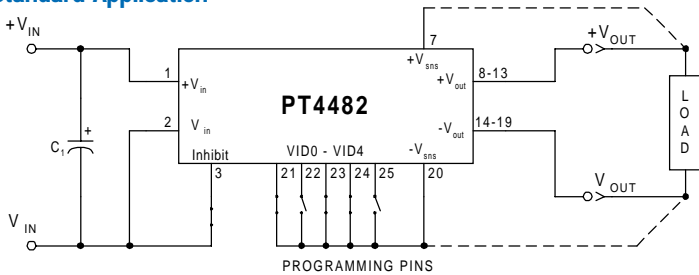

- C1 = Optional 33µF, 100V electrolytic capacitor
- Programming pins, VID0-VID4, are shown configured for Vo = 3.3V
- For normal operation, pin 3 (Inhibit) must be connected to -Vin.
- For operation with the compatible current booster module, consult the PT4499 data sheet.
- Pins 4, 5, & 26 are used for booster applications only.

Specifications

Characteristics (T _a =25°C unless noted)	Symbols	Conditions (V _{in} =48V, V _o =3.3V unless noted)	PT4482			Units
			Min	Typ	Max	
Output Current	I _o	Over V _{in} range	0	—	30	A
Current Limit	I _{cl}	V _{in} = 36V	—	35	—	A
Current Sharing		with PT4499 current booster	—	±10	—	%
Input Voltage Range	V _{in}	I _o = 0 to max I _o	36	48	75	V
Output Voltage Tolerance	ΔV _o	Over V _{in} Range T _A = -40 to +100°C Baseplate	—	±1.0	±2.0	%V _o
Line Regulation	Reg _{line}	Over V _{in} range @ max I _o	—	±0.1	±1.0	%V _o
Load Regulation	Reg _{load}	0 to 100% of I _o max	—	±0.5	±1.0	%V _o
V _o Ripple/Noise	V _n	I _o = I _o max	V _o > 2.0V V _o ≤ 2.0V	60 45	75 55	mV _{pp}
Transient Response	t _{tr}	50% to 75% I _o max @ 0.1A/µs V _o over/undershoot (no ext caps)	—	N/A 1.0	—	µSec %V _o
		50% to 100% I _o max @ 1.0A/µs V _o over/undershoot (no ext. caps)	—	75 6	—	µSec %V _o
V _o Rise Time	V _{otr}	At turn-on	—	—	10	mSec
Efficiency	η	I _o =15A	—	88.5	—	%
Switching Frequency	f _o	—	—	300	—	kHz
Remote On/Off	Off On	Open or 2.5 to 5.1 VDC above -V _{in} Short or 0 to 0.8 VDC above -V _{in}				
Over-Voltage Protection	OVP	Shutdown and latch off	—	125	—	%V _o
Isolation	—	—	1500	—	—	VDC
Maximum Operating Temperature Range	T _c	Measured at center of case	-40	—	+100	°C
Over-Temperature Shutdown Point	OTP	Case temperature - Auto reset	—	+105	—	°C
Reliability	MTBF	Per Bellcore TR-332 50% stress, t = 40°C, ground benign	1.4	—	—	10 ⁶ Hrs
Mechanical Shock	—	Per Mil-STD-883D, Method 2002.3, 1mS, Half-sine, mounted to a fixture	—	TBD	—	G's
Mechanical Vibration	—	Per Mil-STD-883D, Method 2007.2, 20-2000Hz, Soldered in a PC board	—	TBD	—	G's
Weight	—	—	—	90	—	grams

PT4482—48V

100 Watt 30 Amp Programmable Isolated DC-DC Converter

Pin-Out Information

Pin	Function	Pin	Function
1	+V _{in}	14	-V _{out}
2	-V _{in}	15	-V _{out}
3	Inhibit	16	-V _{out}
4	V _r	17	-V _{out}
5	V _a	18	-V _{out}
6	Not used	19	-V _{out}
7	+V _{sense}	20	-V _{sense}
8	+V _{out}	21	VID0
9	+V _{out}	22	VID1
10	+V _{out}	23	VID2
11	+V _{out}	24	VID3
12	+V _{out}	25	VID4
13	+V _{out}	26	DRV

Programming Information

VID3	VID2	VID1	VID0	VID4=1 V _{out}	VID4=0 V _{out}
1	1	1	1	2.0V	1.30V
1	1	1	0	2.1V	1.35V
1	1	0	1	2.2V	1.40V
1	1	0	0	2.3V	1.45V
1	0	1	1	2.4V	1.50V
1	0	1	0	2.5V	1.55V
1	0	0	1	2.6V	1.60V
1	0	0	0	2.7V	1.65V
0	1	1	1	2.8V	1.70V
0	1	1	0	2.9V	1.75V
0	1	0	1	3.0V	1.80V
0	1	0	0	3.1V	1.85V
0	0	1	1	3.2V	1.90V
0	0	1	0	3.3V	1.95V
0	0	0	1	3.4V	2.00V
0	0	0	0	3.5V	2.05V

Logic 0 = Pin 20 potential (remote sense gnd)
 Logic 1 = Open circuit (no pull-up resistors)
 VID4 may not be changed while the unit is operating.

Ordering Information

PT4482□ = 1.3 to 3.5 Volts
 (For dimensions and PC board layout, see Package Styles 1200, 1210 and 1215.)

PT Series Suffix (PT1234X)

Case/Pin Configuration

Vertical Through-Hole	N
Horizontal Through-Hole	A
Horizontal Surface Mount	C

TYPICAL CHARACTERISTICS

PT4482, V_o = 3.3V (See Note A)

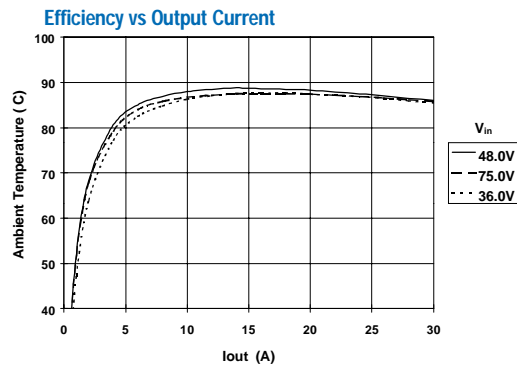

Safe Operating Area, V_{in} = 48V, V_o = 3.3V (See Note B)

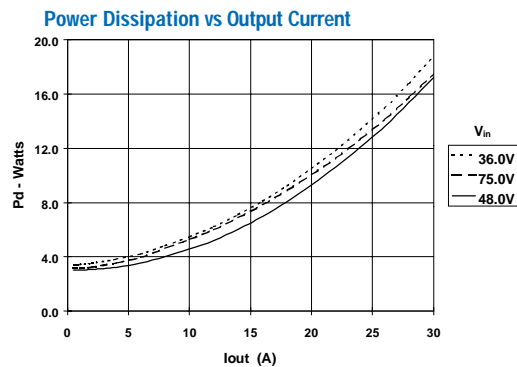
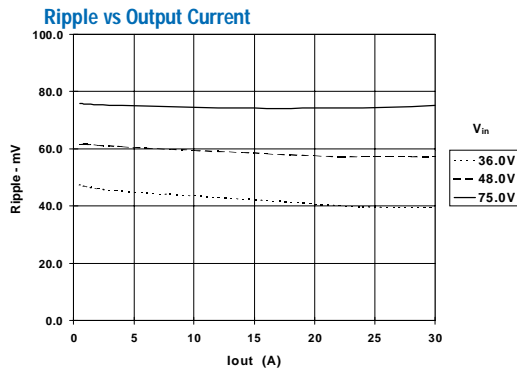
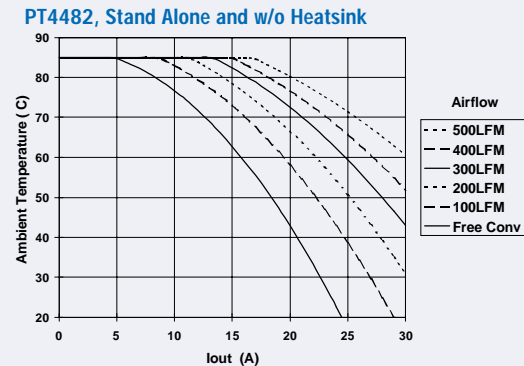

Note A: All data listed in the above graphs has been developed from actual products tested at 25°C. This data is considered typical data for the DC-DC Converter.
 Note B: SOA curves represent operating conditions at which the temperature of the metal case is at or below the maximum specified 100°C

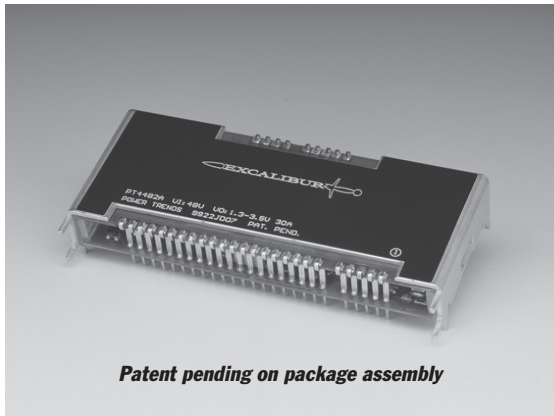

Patent pending on package assembly

- 30A Current Boost (Boosts PT4482 to 60A)
- Tracks V_{out} of PT4482
- Synchronized Operation
- High Efficiency
- Input Voltage: 36V to 75V
- 26-pin Copper Case Package

The PT4499 is a new high-performance 30A "Current Booster" for use with the PT4482 Excalibur™ DC/DC converter. The PT4499 adds a parallel output stage to the PT4482, allowing both to operate in perfect synchronization.

The PT4499 only operates with a PT4482 and is not a stand-alone product. Refer the PT4482 data sheet for the performance specifications. The PT4499 is housed in the same 26-pin case and has the package options as the PT4482.

PT Series Suffix (PT1234X)

Case/Pin Configuration	
Vertical Through-Hole	N
Horizontal Through-Hole	A
Horizontal Surface Mount	C

Ordering Information

PT4499 □

(For dimensions and PC Board layout, see Package Styles 1200, 1210 and 1215.)

Pin-Out Information

Pin	Function	Pin	Function	Pin	Function
1	+V _{in}	10	+V _{out}	19	-V _{out}
2	-V _{in}	11	+V _{out}	20	-V _{sense}
3	N/C	12	+V _{out}	21	N/C
4	V _r	13	+V _{out}	22	N/C
5	V _a	14	-V _{out}	23	N/C
6	N/C	15	-V _{out}	24	N/C
7	N/C	16	-V _{out}	25	N/C
8	+V _{out}	17	-V _{out}	26	DRV
9	+V _{out}	18	-V _{out}		

Standard Application

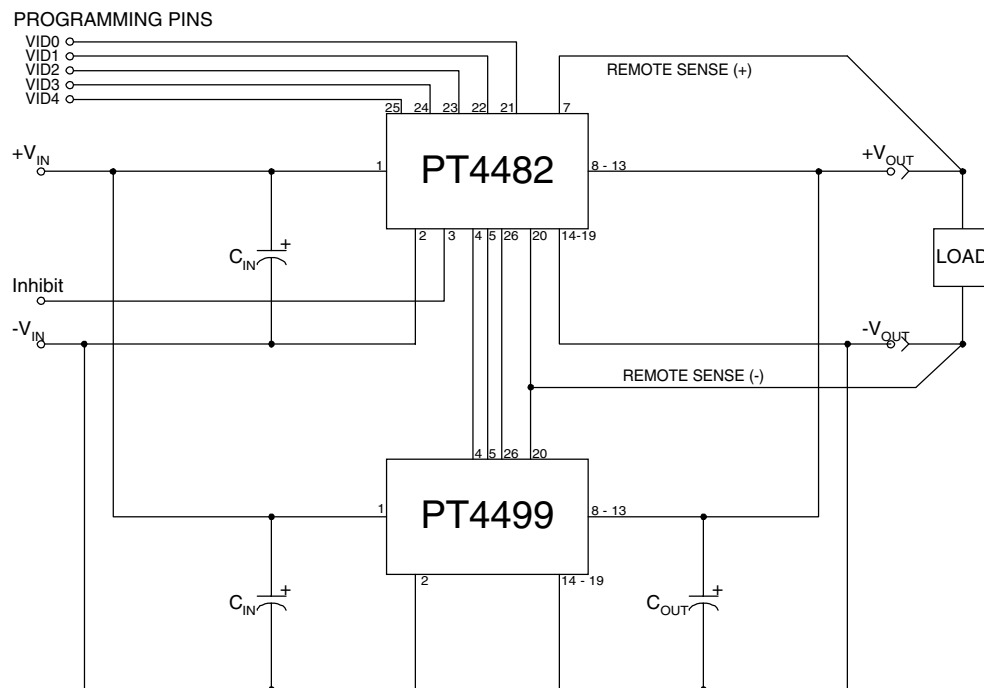

Input Capacitors: Although not necessary for stable operation, C_{in} will reduce input ripple. C_{in} = 33μF is suggested.

Output Capacitors: A minimum of 330μF per PT4499 booster module is required for proper operation. Increasing C_{out} will reduce transients due to large and/or fast load steps.